

# 350Z-TRTN

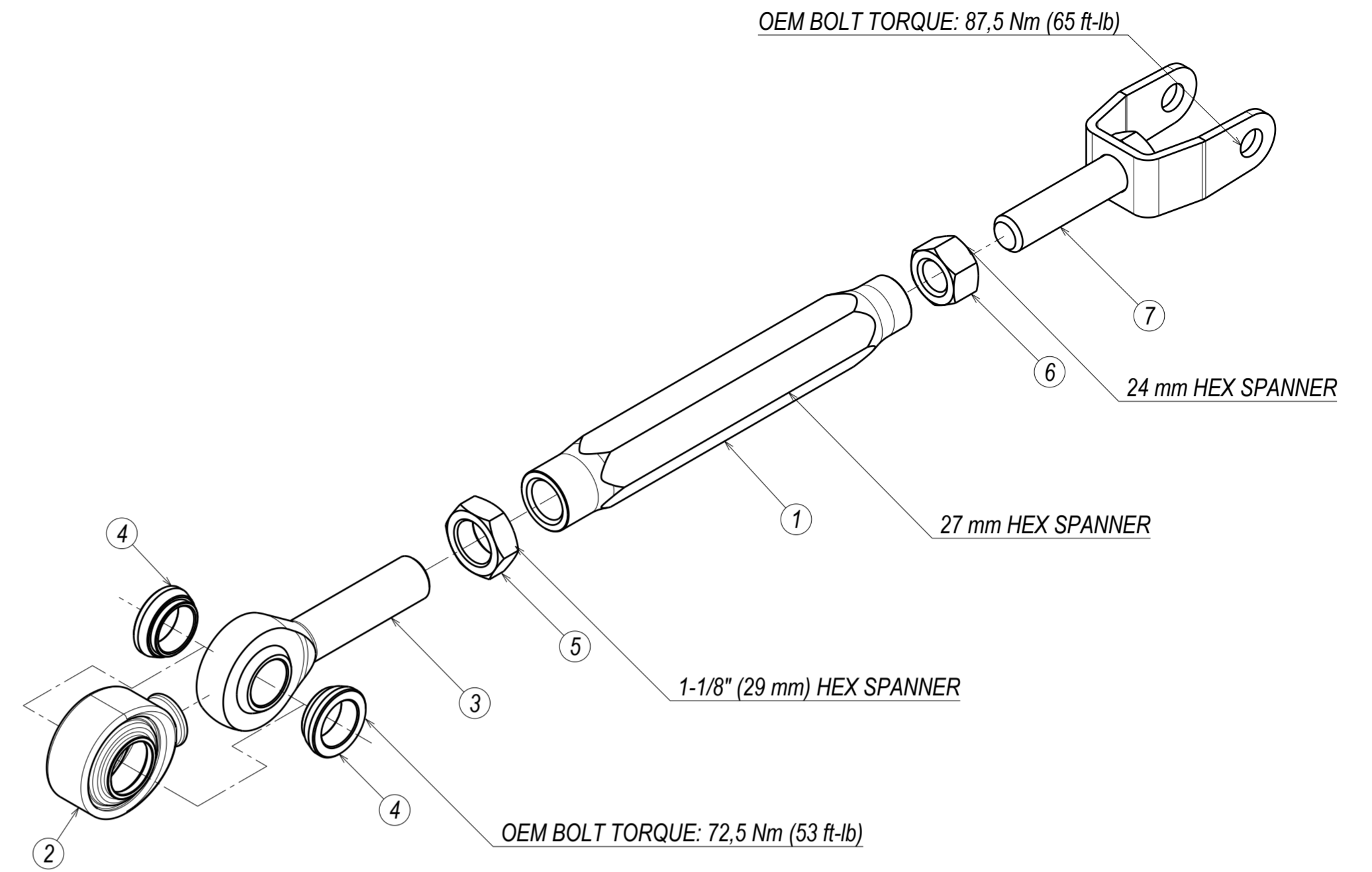
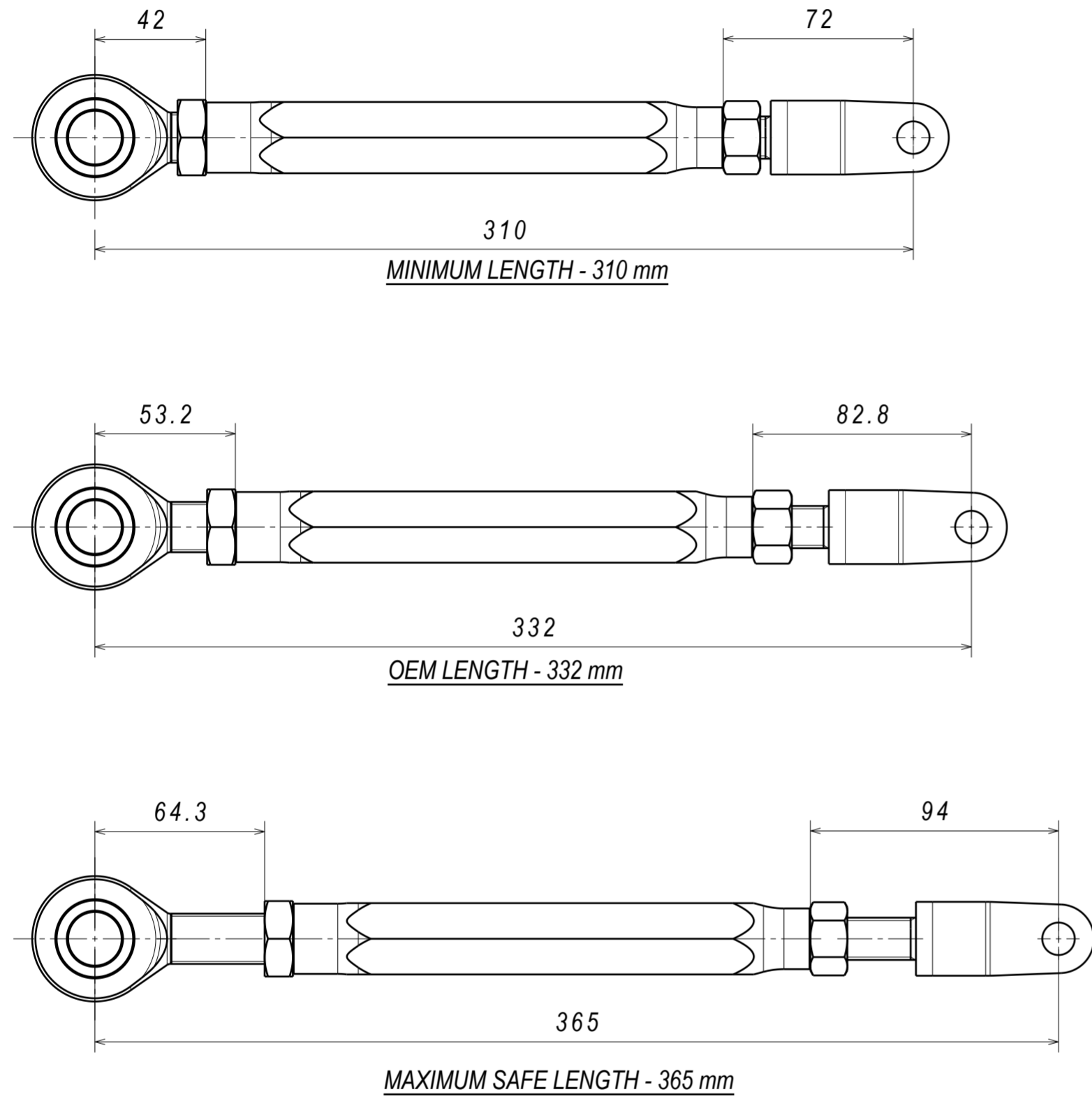

7	350Z TRACTION LINK CLEVIS WELDING ASM	1
6	NUT M16	1
5	LH 3/4-16 ASTM A563 GRADE A ZINC STEEL JAM NUT	1
4	SPACER 20,3x45	2
3	ROD END PCML13T-E	1
2	QA1 PCML12T BOOT REV2	1
1	350Z TRACTION LINK BAR	1
PC NO	COMPONENT NAME	QTY

## CRITICAL!

CHECK FOR ROD END BEARING ALIGNMENT  
AFTER TIGHTENING THE ADJUSTING MECHANISM  
ROD END TO BE PERPENDICULAR TO THE SPACERS

