

REAR-CMBR 1/2

MINIMUM LENGTH - 290mm

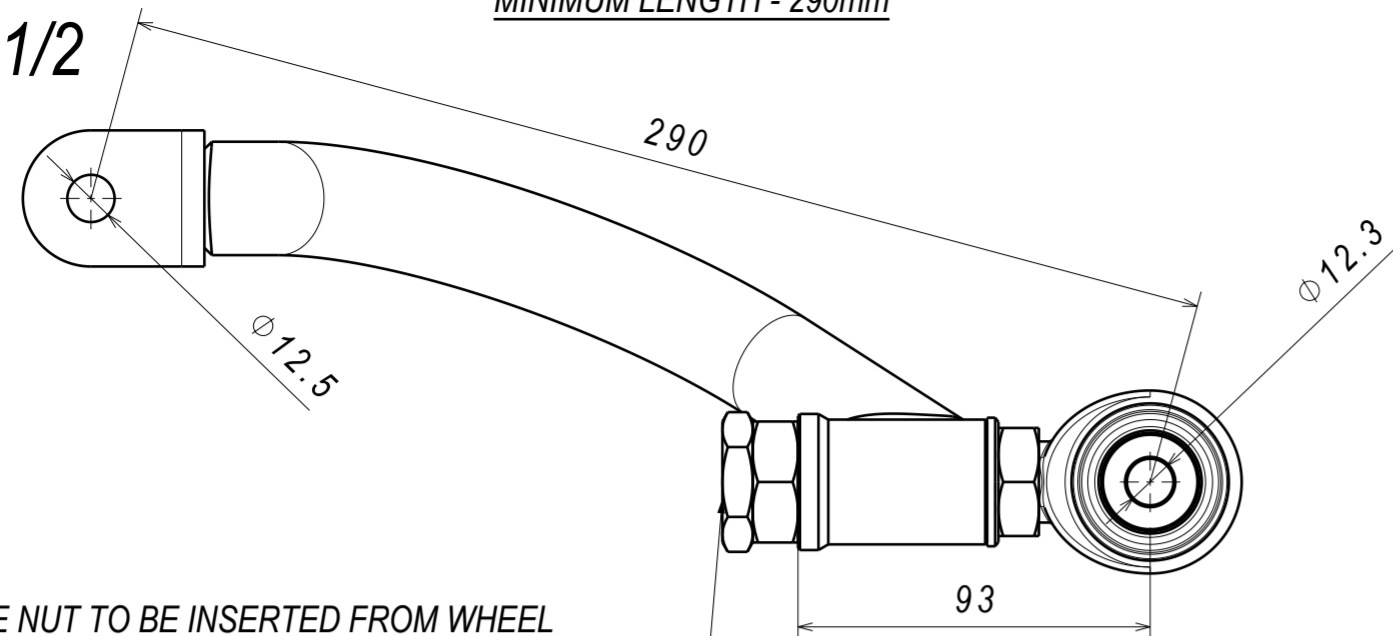

NB! ADJUSTER AND LARGE NUT TO BE INSERTED FROM WHEEL SIDE ON ARM LENGTHS SHORTER THAN OEM (308mm)

NOTE: ADJUSTER WORKS BACKWARDS IN THIS POSITION. WINDING IT IN TOWARDS THE CHASSIS PUSHES THE ROD END OUT

OEM LENGTH - 308mm

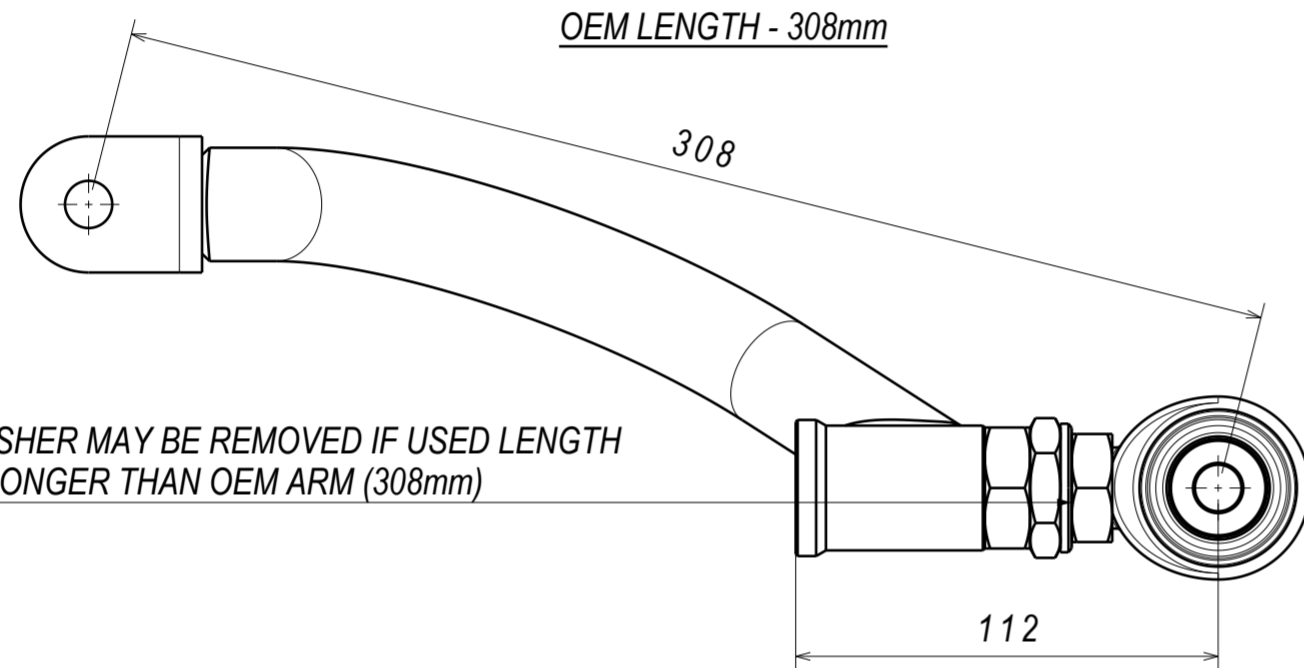

WASHER MAY BE REMOVED IF USED LENGTH IS LONGER THAN OEM ARM (308mm)

MAXIMUM SAFE LENGTH - 348mm

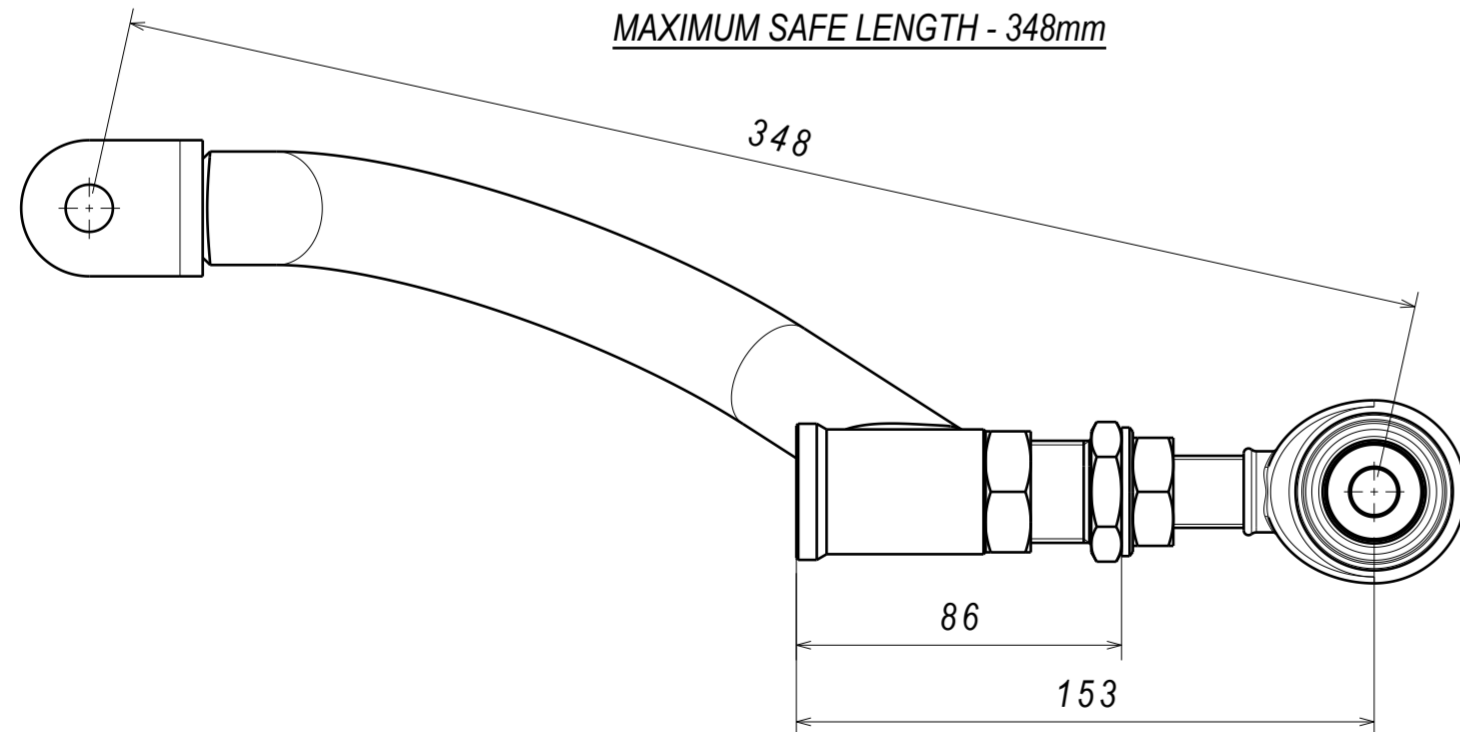

EXPLODED VIEW OF LEFT HAND SIDE REAR CAMBER ARM ASSEMBLY

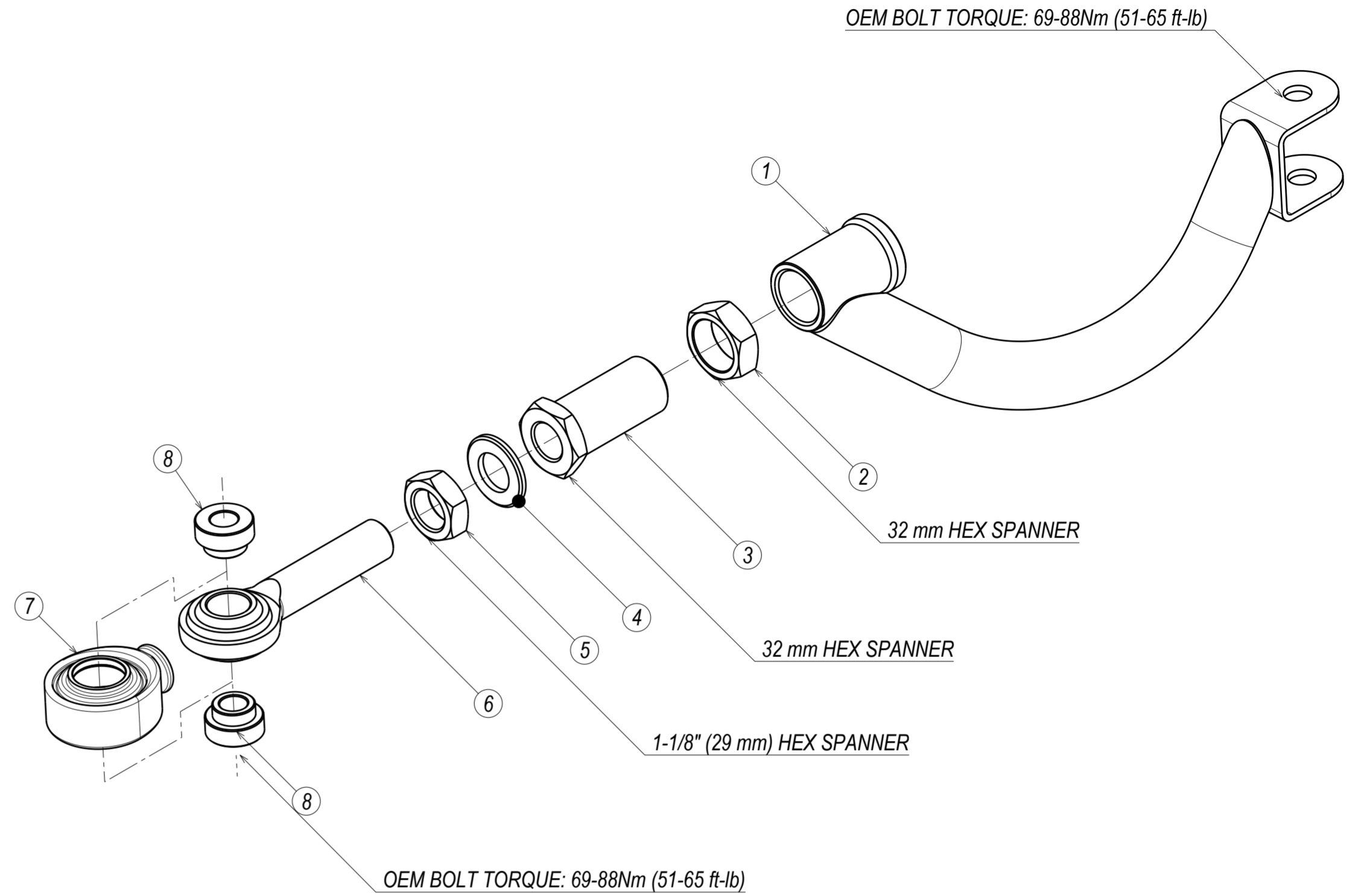

CRITICAL!

CHECK FOR ROD END BEARING ALIGNMENT AFTER TIGHTENING THE ADJUSTING MECHANISM
ROD END TO BE PERPENDICULAR TO THE SPACERS

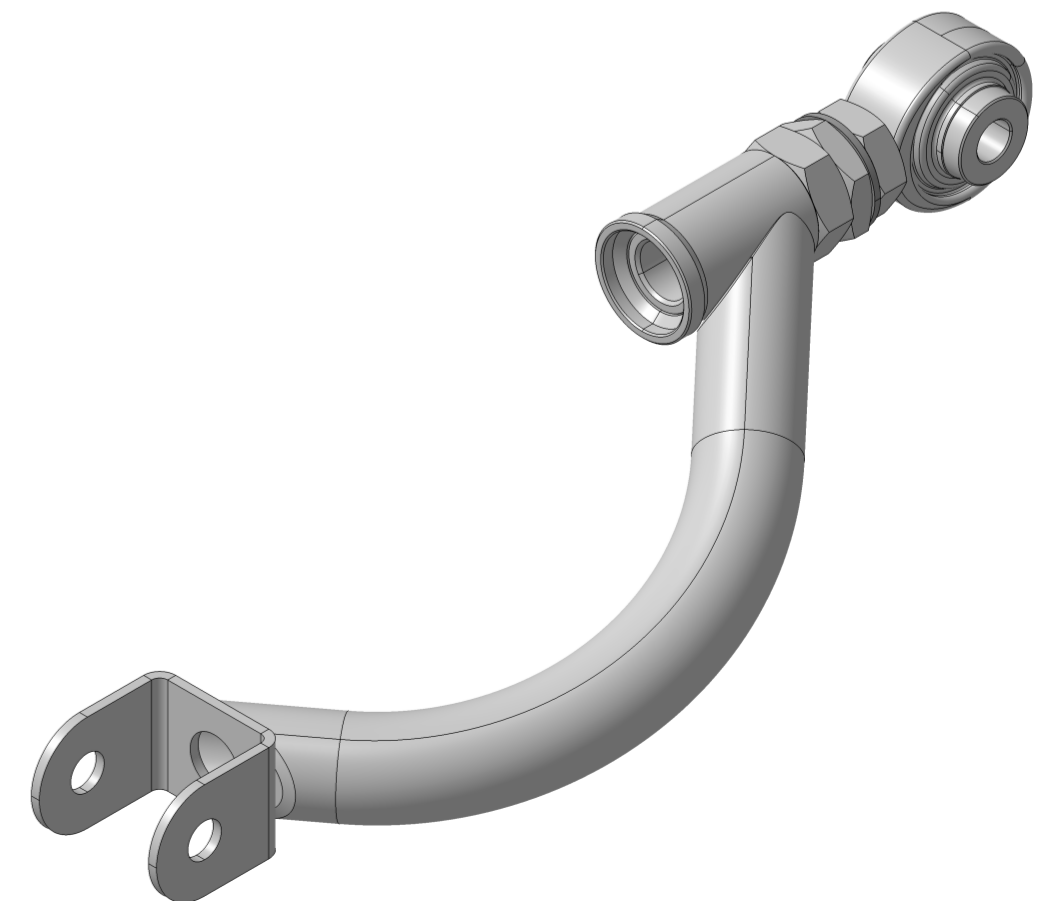

8	SPACER - QA1 PCML12T 12ID 40W	2
7	ROD END COVER PCML12TES	1
6	ROD END PCML12TES	1
5	JAM NUT 3/4-16 UNF 3B LH (HEIGHT 10,7mm)	1
4	ISO 7089 WASHER 18x34 STEEL ZN	1
3	THREAD ADJUSTER - M27x1.5 EXT 3/4-16 UNF LH INT	1
2	M27x2 JAM NUT	1
1	CAMBER ARM BODY	1
PC NO	COMPONENT NAME	QTY