

V413-GRIP V414-GRIP

S13 SPINDLE : TIGHEN NUT TO
135 Nm (100 lbs-ft)

S14 SPINDLE: TIGHTEN NUT TO
150 Nm (110 lbs-ft)

S13 SPINDLE : TIGHEN NUT TO
190 Nm (140 lbs-ft)

S14 SPINDLE: TIGHTEN NUT TO
240 Nm (177 lbs-ft)

TIGHEN TO 85 Nm
(62 lbs-ft)
(OEM CALIPERS)

TIGHTEN NUT TO
70 Nm (50 lbs-ft)

TIGHTEN NUT TO
110 Nm (82 lbs-ft)

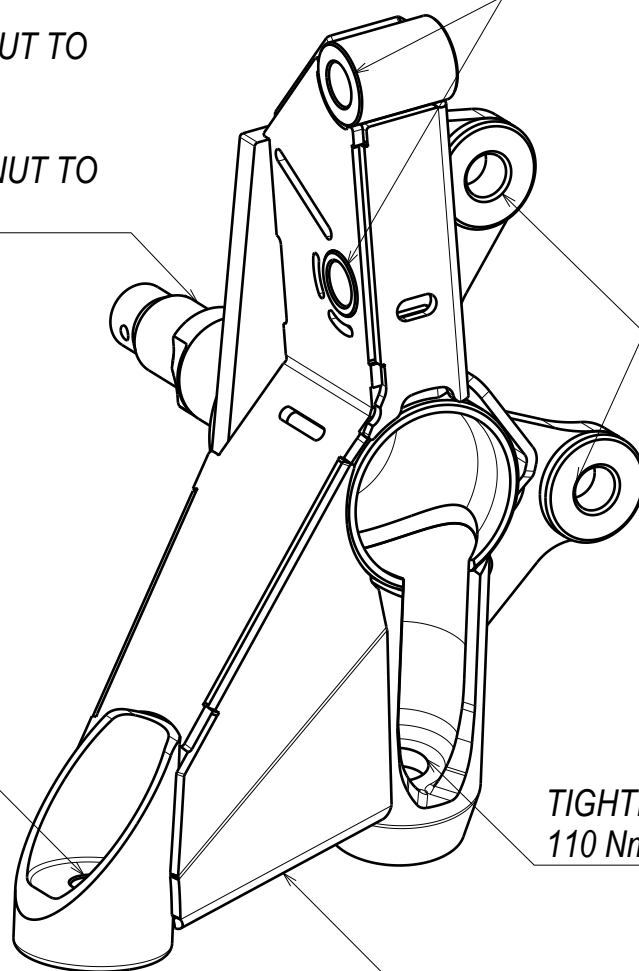

STEERING KNUCKLE

NOTE! S14 S1 comes OEM with a spindle hub washer
S14 S2/S15 does not use a spindle hub washer

The GKTECH knuckles have been designed not to use a spindle hub washer

As such, if you have an S14 S1 the spindle hub washer is to be discarded